

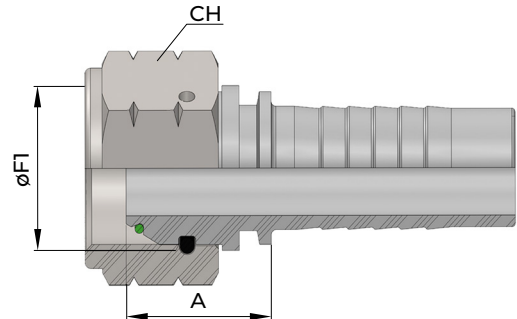

INOX AISI 316

FDM

FEMALE METRIC 60° FLARE THRUST WIRE NUT
FEMMINA METRICA S.V.60° DADO SPINATO



| Part Number | Thread | Hose ID | | CH | cut-off=A | O-RING VITON |
|---------------|--------|---------|------|----|-----------|--------------|
| | F1 | size | mm | mm | mm | |
| FDM010316316* | 10X1 | 3/16" | 4,8 | 14 | 16 | NO |
| FDM010014316* | 10X1 | 1/4" | 6,4 | 19 | 20 | NO |
| FDM014014316 | 14X1,5 | 1/4" | 6,4 | 19 | 20 | NO |
| FDM014516316 | 14X1,5 | 5/16" | 8,0 | 19 | 20 | NO |
| FDM014038316 | 14X1,5 | 3/8" | 9,5 | 19 | 20 | NO |
| FDM016014316 | 16X1,5 | 1/4" | 6,4 | 22 | 21 | NO |
| FDM016516316 | 16X1,5 | 5/16" | 8,0 | 22 | 21 | NO |
| FDM016038316 | 16X1,5 | 3/8" | 9,5 | 22 | 21 | NO |
| FDM016012316 | 16X1,5 | 1/2" | 12,7 | 22 | 21 | NO |
| FDM018014316 | 18X1,5 | 1/4" | 6,4 | 24 | 21 | NO |
| FDM018516316 | 18X1,5 | 5/16" | 8,0 | 24 | 21 | NO |
| FDM018038316 | 18X1,5 | 3/8" | 9,5 | 24 | 21 | NO |
| FDM018012316 | 18X1,5 | 1/2" | 12,7 | 24 | 21 | NO |
| FDM022038316 | 22X1,5 | 3/8" | 9,5 | 27 | 23 | SI |
| FDM022012316 | 22X1,5 | 1/2" | 12,7 | 27 | 22 | SI |
| FDM022058316 | 22X1,5 | 5/8" | 16,0 | 27 | 22 | SI |
| FDM026012316 | 26X1,5 | 1/2" | 12,7 | 32 | 27 | SI |
| FDM026058316 | 26X1,5 | 5/8" | 16,0 | 32 | 26 | SI |
| FDM026034316 | 26X1,5 | 3/4" | 19,0 | 32 | 26 | SI |

* DADO PRESSATO | PRESSED NUT